

INTERNATIONAL JOURNAL OF ENGINEERING SCIENCES & MANAGEMENT MODELING AND SIMULATION OF SINGLE PHASE GRID CONNECTED PV SYSTEM

Prof. E. Vijay Kumar^{*1}, Santosh S. Negi² & Nirali Gandhi³

^{*1}Head of the Department, Department of Electrical Engineering, R.K.D.F. Institute of Science & Technology, Bhopal, Madhya Pradesh, India

²Assistant Professor, Department of Electrical Engineering, R.K.D.F. Institute of Science & Technology, Bhopal, Madhya Pradesh, India

³M. Tech (Power Electronics), Department of Electrical Engineering, R.K.D.F. Institute of Science & Technology, Bhopal, Madhya Pradesh, India

ABSTRACT

This is employed in the PV system to obtain a high performance. A single phase grid connected with a photovoltaic (PV) power system that will provide high voltage gain with state model analysis for the control of the system has been presented. First the photovoltaic system is designed and simulated using MATLAB SIMULINK software. The output voltage of a PV array is comparatively low thus high voltage gain is necessary for grid-connection and synchronization. The PV system has been provided with a boost converter which will boost the low voltage of the PV array to high dc-voltage. A steady state model is obtained and is verified with the help of simulation. A full bridge inverter with bidirectional power flow is used as the second power processing stage, which stabilizes the dc voltage and the output current. Further, a maximum-power-point-tracking method is employed in the PV system to obtain a high performance.

Keywords: *Photovoltaic, Maximum power point tracking, Matlab, simulink, boost Converter, Inverter.*

I. INTRODUCTION

Amongst the renewable source of energy, the photovoltaic power systems are gaining popularity, with heavy demand in energy sector and to reduce environmental pollution around caused due to excess use non-renewable source of energy. Several system structures are designed for grid connected PV systems. Four different kinds of system configuration are used for grid connected PV power application: the centralized inverter system, the string inverter system, the multi-string inverter system and the module integrated inverter system.

The main advantages of using a grid connected PV systems are: effect on the environment is low, they can be installed near to the consumer, thereby transmission line losses can be saved, cost of maintenance in the generating system can be reduced as there are no moving parts, system's modularity will allow the installed capacity to expand and carbon-dioxide gases are not emitted to the environment.

For small distributed generator system, such as residential power utilization, all the above mentioned types of inverters system other than centralized inverter system are used. The main problem in the design of the photovoltaic distributed generator system is to obtain high voltage gain. For a typical photovoltaic model, the open circuit voltage is about 20 V and the maximum power point (MPP) voltage is about 16 V whereas voltage of the utility grid is 220Vac. Hence high voltage amplification is mandatory for grid synchronization and to achieve low total harmonic distortion (THD). In grid-connected PV system power electronics inverters are used for the power conversion, interconnection and control optimization. The steady state analysis and control strategy of the system play a vital role in the grid synchronization. The output of the inverter should be properly sinusoidal for proper grid synchronization. Hence it is clear that inverter required for PV system, high power factor, low THD, fast dynamic response on how the control strategy are adopted for grid inverters.

Ensuring current injected into the grid with low harmonic content and maintain the phase with the main voltage, the controller must be able to track down maximum power point tracking (MPPT) mechanism using perturb and observe

(P&O) algorithm for the PV model which will cause all the available array power to be utilized. Figure 1 show the Layout of Single phase grid connected PV system.

It is mandatory that the most of the solutions designed to attain the PV system tasks such as MPPT, in inverter and Power factor correction are employed at two different stages.

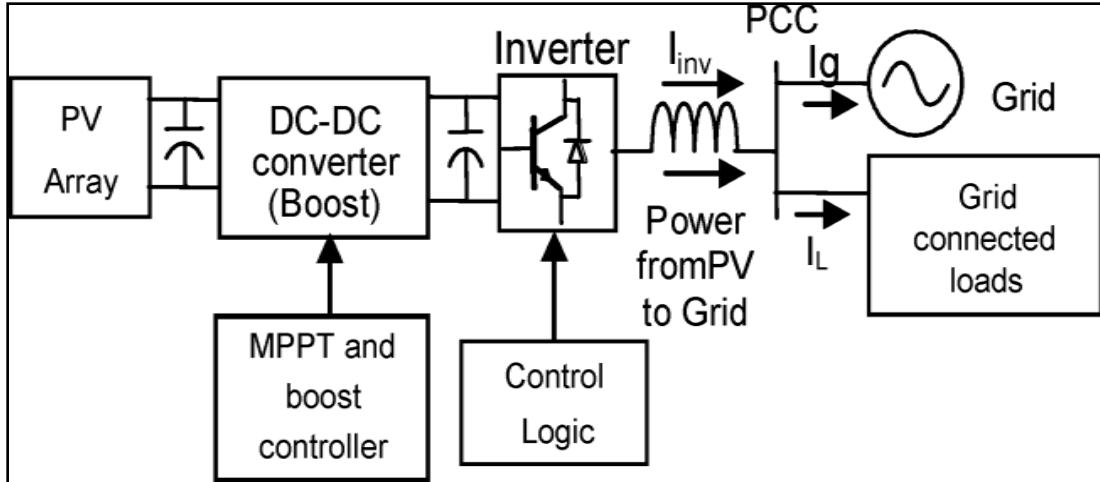

Figure 1: Layout of Single phase grid connected PV system.

II. MODELING OF SOLAR CELL AND MPPT

In this section, modeling of PV array and whole system is presented along with their respective simulation results and analysis.

Solar Cell: To understanding on the operation and electrical equivalent circuit of single solar cell will be discussed. Referring to Figure 2, without the sun light (dark), the solar cell shall function as a normal diode. If any external supply connects to it, the solar cell will function and produce the diode current (I_D). In the dark, the solar cell will not produce any electric current or voltage. This solar cell model consists of a current source (I_{ph}), series resistance (R_s) which representing the resistance inside the each cell as well in the connection between the cells, and a diode. The difference between I_{ph} and I_D will give the net current output from the solar cell.

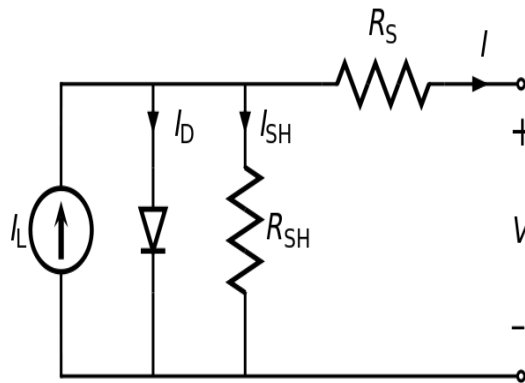

Figure 2: Equivalent Circuit for Solar Cell

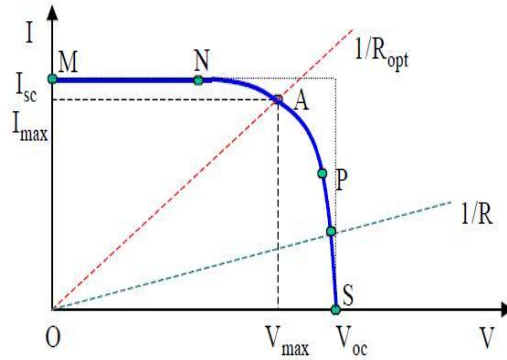

Figure 3: A typical current-voltage (I-V) curve For a solar cell.

The mathematical equation for solar cell can be represented as in equation 1. The equation is actually using Kirchhoff Current Law (KCL) and also diode Shockley equation. The m is the representation of idealizing factor, k Boltzmann’s gas constant, T_c will be absolute temperature of the cell, e will be electric charge, and V will be the voltage implied across the cell. I_0 is saturation current in dark surroundings and depends on the temperature

$$I = I_{ph} - I_D = I_{ph} - I_0 \left(\exp \frac{e(V + IR_s)}{mkT_c} - 1 \right) \tag{1}$$

Maximum efficiency in the solar cell context means the ratio between incident light power and maximum power. The equation 2 depicts clearly and as G_a is the ambient irradiation as well the A is the cell area.

$$\eta = \frac{P_{max}}{P_{in}} = \frac{I_{max} V_{max}}{A G_a} \tag{2}$$

Figure 3 and Figure 4 show the Simulink model for PV array and Simulation output.

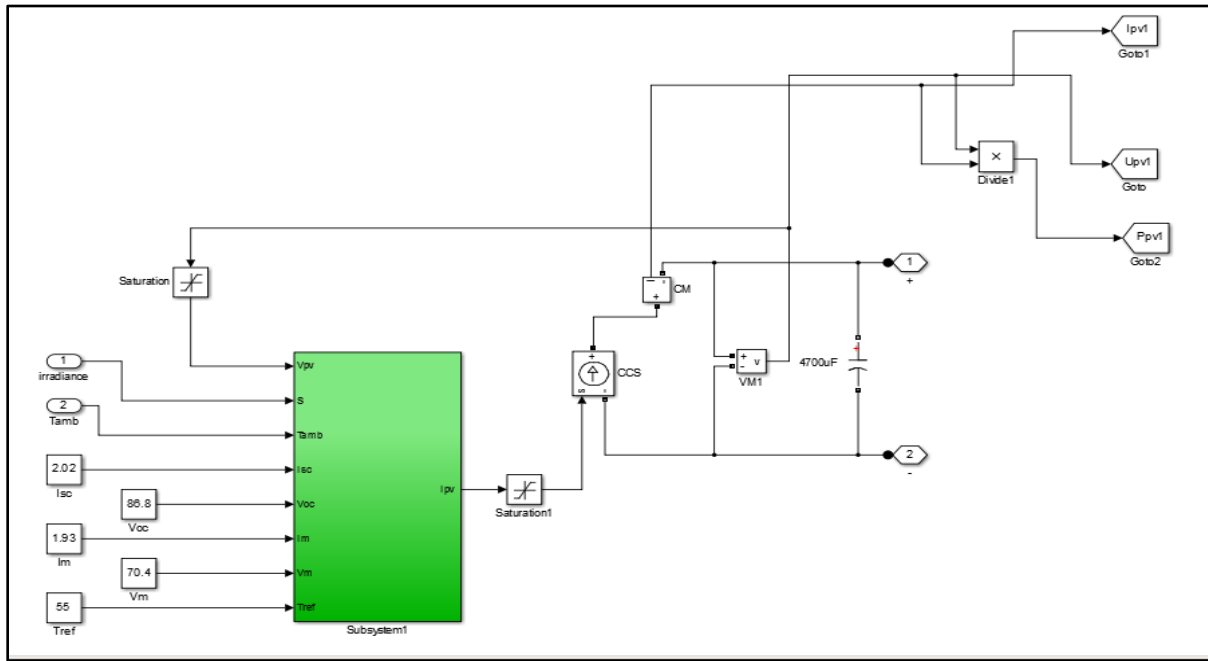

Figure 3: Matlab Simulink Model for PV Array

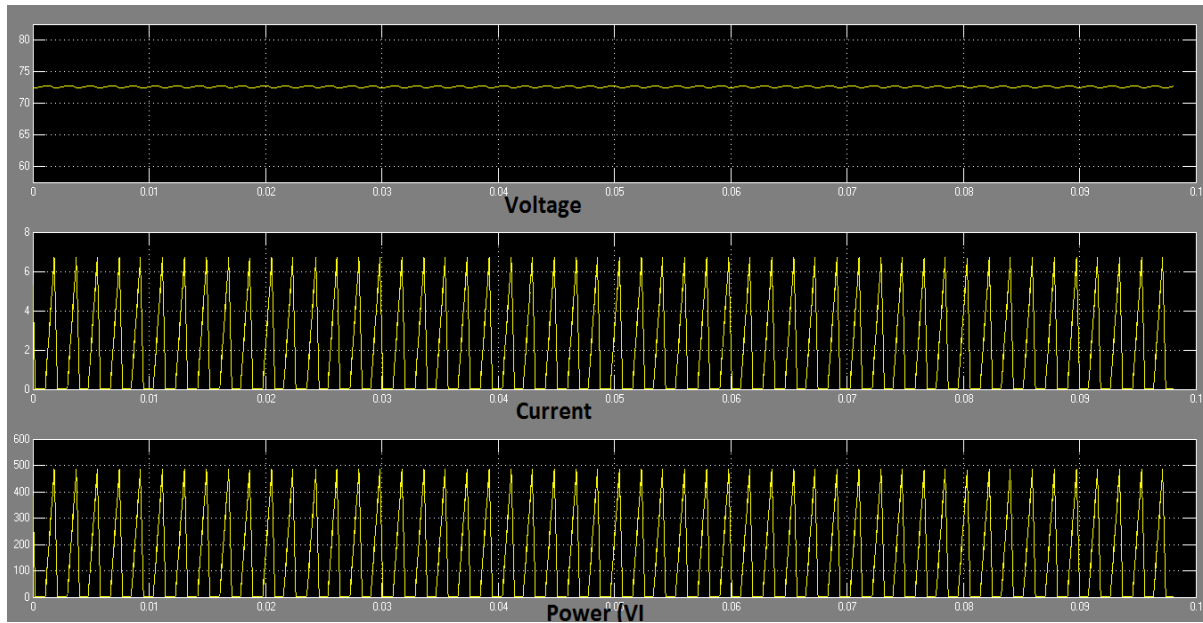

Figure 4: Simulation output of PV array

These were the parameter which were applied for Simulation for PV array.

Irradiance	=	1000
Ambient Temperature Tamb	=	25°C
Short Circuit current Isc	=	2.02 A
Maximum Current Im	=	1.93 A
Open Circuit Voltage Voc	=	86.8 V
Maximum voltage Vm	=	70.4 V

MPPT: There are different methods are there for maximum power point tracking but we have used Perturb and Observe algorithm Method which gives higher stability and higher performance.

Perturb and Observe is the most regularly utilized MPPT strategy because of its simplicity of execution. The working voltage is expanded the length of $(dP)/dV$ is sure, i.e. the voltage is expanded the length of we get more power. On the off chance that $(dP)/dV$ is detected negative, the working voltage is diminished. The voltage is kept put if $(dP)/dV$ is close to zero inside of a preset band. The time multifaceted nature of this calculation is less however oncoming to near to the MPP it doesn't stop at the MPP and continues annoying. This calculation is not suitable when the variety in the sun oriented illumination is high. The voltage never really achieves a careful esteem yet annoys around the most extreme force point (MPP).Figure 5 and figure 6 MPPT simulation block and its simulation output respectively.

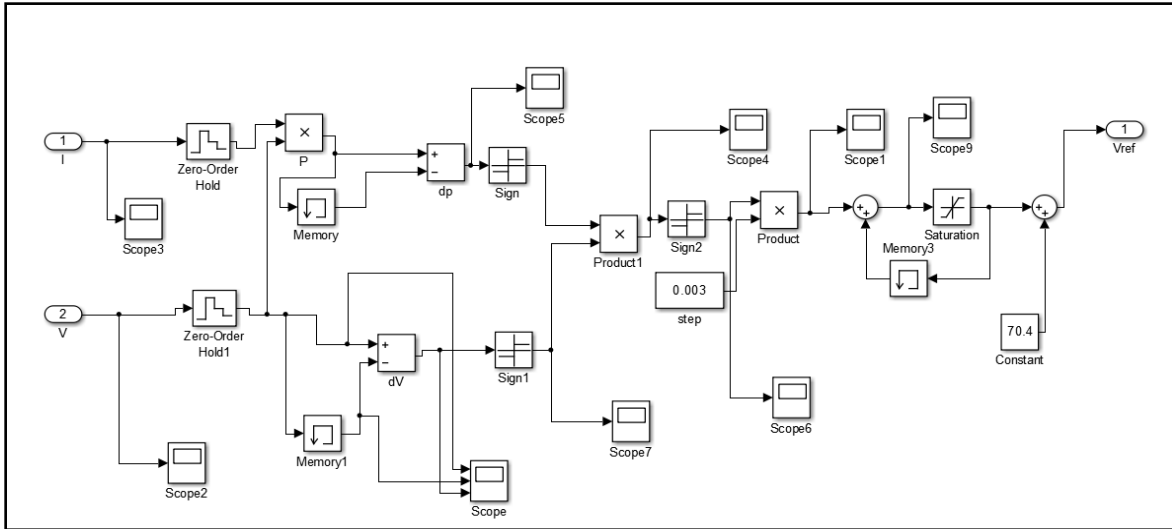

Figure 5: MPPT Simulink Model

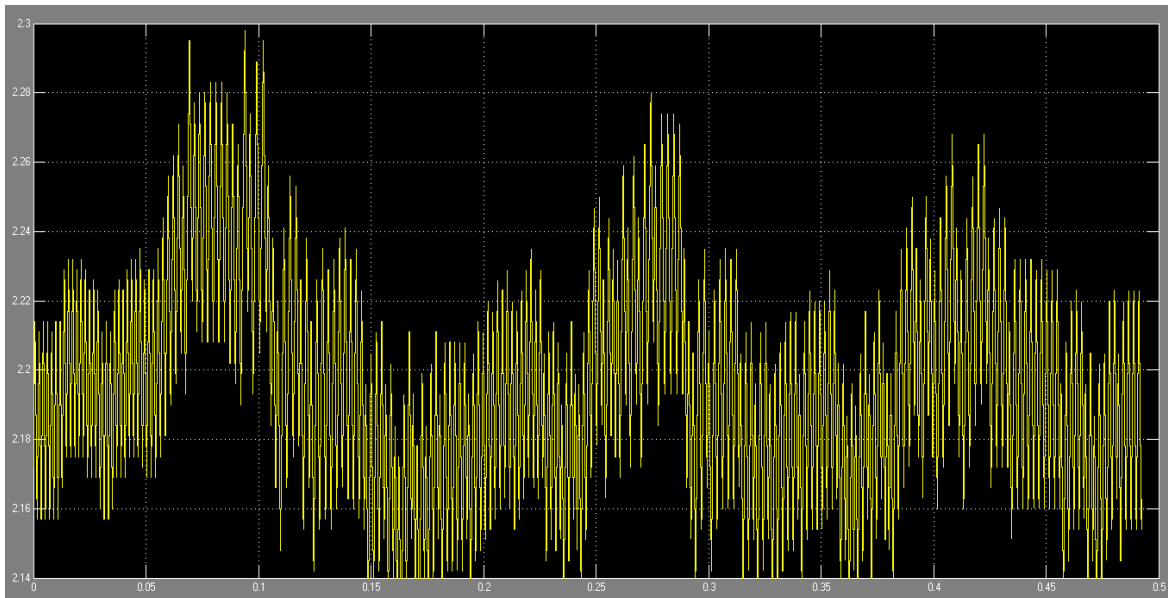

Figure 6: Simulation output MPPT.

Boost Converter: In a boost converter, the output voltage is greater than the input voltage –hence the name “boost”. The ideal PWM functions as the switch control and the transistor acts as the switch element. The diode and the capacitor are used to perform the function of the output rectifier and filter block. Figure 7 and figure 8 show the simulink model for boost converter and its output respectively.

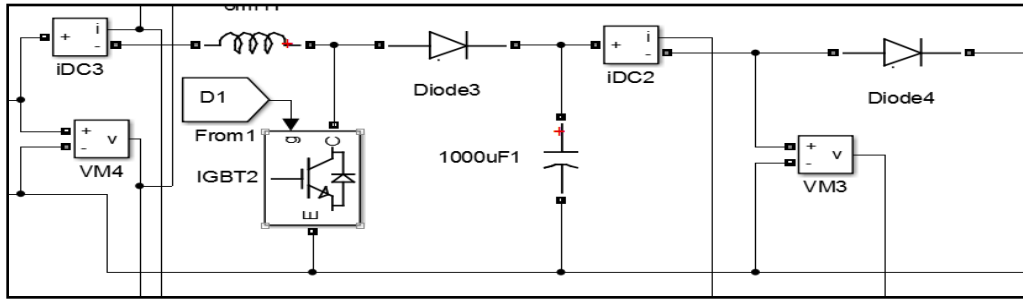

Figure 7: Simulation model of Boost Converter

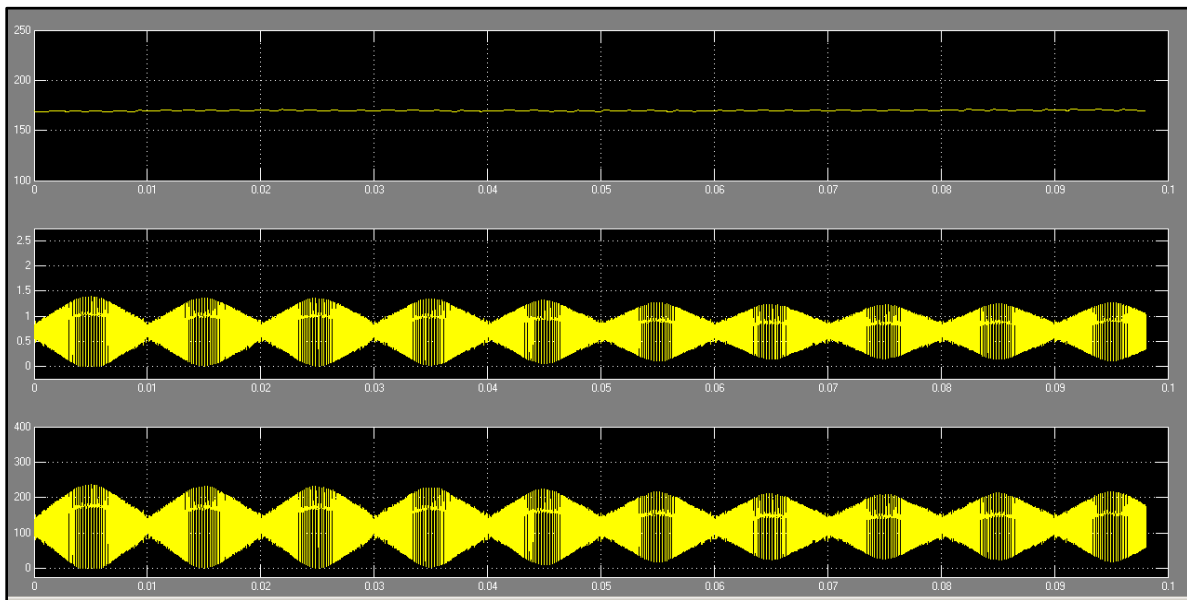

Figure 8: Simulation output Boost Converter

III. MODELING AND SIMULATION RESULT OF PV SYSTEM

Whole PV system contains different blocks like Boost Converter, Inverters, Boost converter, MPPT and some other control circuits. Figure 9 and 10 show the simulink model of whole single phase grid connected PV system and final inverter output.

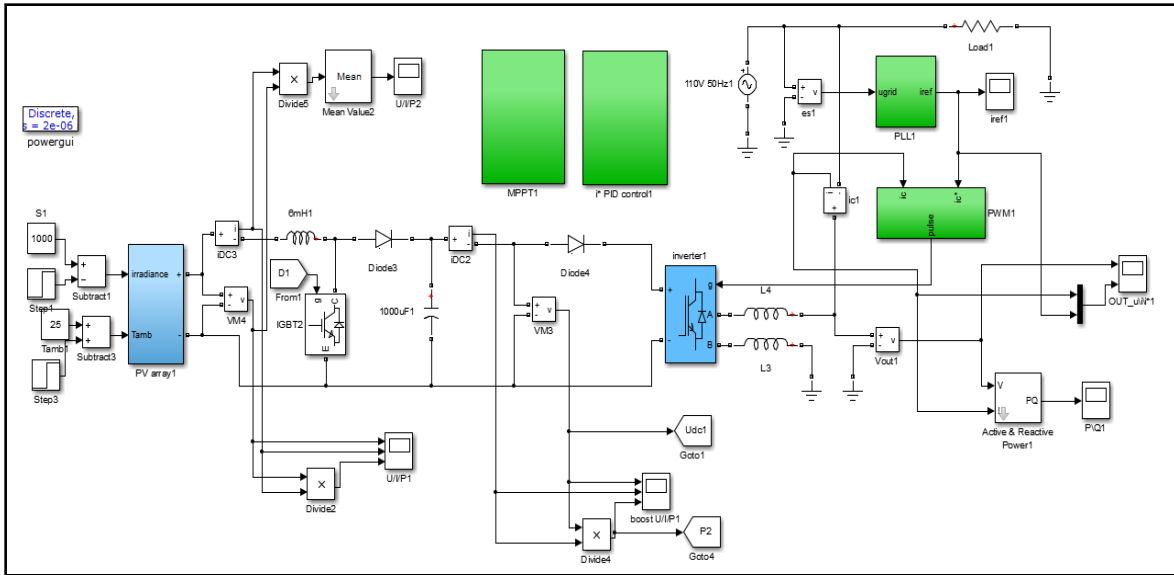

Figure 9: Simulink Model for Single phase grid connected PV system

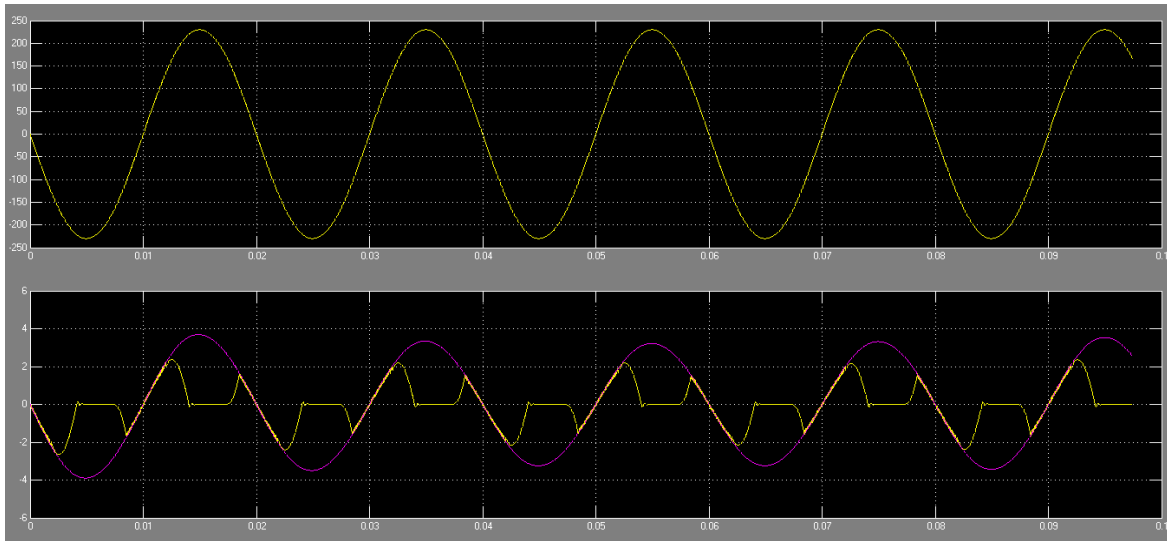

Figure 10: Simulation out of Inverter (Time vs Voltage)

IV. CONCLUSION

A PWM generator was utilized for generating the pulse signal that was compared with the signal generated from the MPPT unit to give out the gating signal to the switch. If MPPT had not been used, then the user would have had to input the duty cycle to the system. When there is change in the solar irradiation the maximum power point changes and thus the required duty cycle for the operation of the model also changes. But if constant duty cycle is used then maximum power point cannot be tracked and thus the system is less efficient. The various waveforms were obtained by using the plot mechanism in MATLAB. There is a small loss of power from the solar panel side to the boost converter output side. This can attributed to the switching losses and the losses in the inductor and capacitor of the boost converter.

The parameters of the inverter model like the inductance, the dc gain and time constant considerably affect the system dynamics at the switching time and should be chosen properly to obtain a stable periodic behavior. When instead of PV, DC source is connected the voltage waveform is quite similar to the reference voltage but both

current and voltage has some harmonic content in them. After connecting the PV module the harmonic content in current and voltage increased and the output of the PV was also affected considerably. A Linear PLL (LPLL) is used for synchronization for single phase signals with acceptable results and a Synchronous Reference Frame (SRF) PLL are used for 3-phase balanced signals. But it cannot be used for unbalanced utility conditions as the detected phase angle contains 2nd harmonic oscillations.

REFERENCES

- [1] *Matlab and Simulink, the Math works, Inc. as of December 2013, <http://www.mathworks.com>.*
- [2] O. Wasynczuk, "Dynamic behavior of a class of photovoltaic power systems," *IEEE Transactions on Power Apparatus and Systems*, vol.PAS-102, no. 9, 1983, pp. 3031-3037.
- [3] O. Wasynczuk, "Modeling and dynamic performance of a line commutated photovoltaic inverter system, " *IEEE Transactions on Energy Conversion*, vol. 4, no. 3, 1989, pp. 337-343.
- [4] M. Chael, E. Ropp, and Sigifredo Gonzalez, "Development of a MATLAB/Simulink model of a single phase grid connected photovoltaic system," *IEEE Transaction on Energy Conversion*, vol3,pp. 344-349, 2009.
- [5] Katsuma Ono, Toshimichi Saito, "Optimization of Switching Rule in DC/AC Inverter by PSO," *IEICE Technical Report of NC*, NC2009-108, 2008.
- [6] N. S. Choi, J. G. Cho, G. H. Cho, "A General Circuit Topology of Multilevel Inverter," *Power Electronics Specialists Conference, 1991. PESC' 91. 1991 IEEE 22th Annual Volume, 24-27 June 1991* pp. 96 – 103.
- [7] H. Fujita, "A three-phase voltage-source solar power conditioner using a single-phase PWM control method," in *Proc. of IEEE Energy Conversion Congress and Exposition*, pp. 3748-3754,2009.
- [8] Yan Xu, L. M. Tolbert, F. Z. Peng, J. N. Chiasson, and J. Chen, "Compensation-based non-active power definition," *IEEE Power Electronics Letters*, vol. 1, no. 2, June 2003, pp. 45-50, June 2003.
- [9] R. Faranda, S. Leva, V. Maugeri, "MPPT techniques for PV Systems: energetic and cost comparison" *IEEE Power and Energy Society General Meeting – Conversion and Delivery of Electrical Energy in the 21st Century*", pp. 1-6, July 2008.
- [10]Santosh S. Raghuwanshi , Kamlesh Gupta," Modeling of a Single-Phase Grid-ConnectedPhotovoltaic System Using MATLAB/Simulink", *IEEE International Conference on Computer, Communication and Control -2015*.
- [11]Jozef Sedo, Slavomir Kascak, "Control of Single-Phase Grid Connected Inverter System",*IEEE Internationa – 2016*
- [12]Sandeep. N , Udaykumar R.," Single-Phase Seven-Level Grid-Connected Photovoltaic System with Ripple Correlation Control Maximum Power Point Tracking", *INTERNATIONAL JOURNAL of RENEWABLE ENERGY RESEARCH* N. Sandeep and R.Y. Udaykumar , Vol.6, No.4, 2016